

mesytec **MUX-16** is a very fast 16 channel multiplexed preamplifier shaper and discriminator combination with very good energy and timing resolution. Up to two simultaneously responding channels are identified and two amplitudes plus the two corresponding amplitude coded addresses are switched to a bus. Up to eight modules (128 channels) can be connected to one bus, so only 4 channels of peak sensing ADCs are needed to digitize energy and position signals. The modules are especially well suited for single hit applications (maximum two hits on one module) with single or double sided multistrip silicon detectors or multiwire proportional chambers. Due to low power consumption the MUX-16 PCB can be used in vacuum without cooling.

Features:

- **High rate:**
up to 800 kHz rate capability per bus
(1.2 us bus dead time per event)
- **Very good timing resolution:**
1 fast leading edge discriminators per channel. Ored NIM timing output, reject output
- **Low noise**
preamplifiers and 5th order shaping amplifier allow very good energy resolution
- **Very flexible:**
sensitivity (and polarity) selectable with rotary switch (or RC) in 8 steps
- **Low power:**
1.45 W for 16 channels
- **Compact:** 185 x 100 x 16 mm³
- **In addition:**
fully remote controllable for use in vacuum
- Includes 16 channels of bias filter (and AC coupling) for bias voltages up to ± 400 V
- Processes single and double hits on one 16 channel unit
- Up to 8 modules = 128 channels on one bus, only 2 or 4 peak sensing ADC channels needed
- Pulser input
- Preamplifier input protection
- Option: individual discriminator thresholds for all channels
- Reject: signal output if more than 2 hits or if module collision on the bus



Schematics:

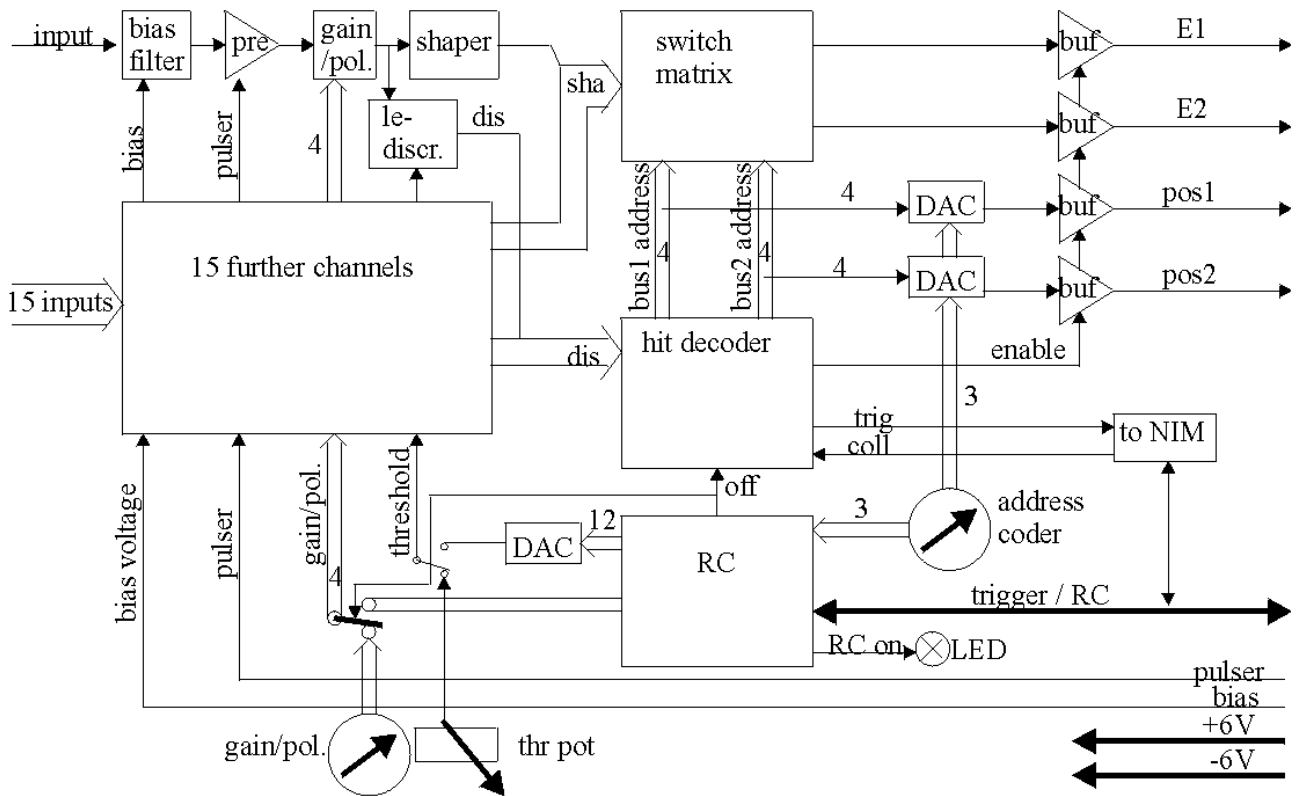

The figure shows a simplified schematic of the MUX-16 device. Signals from the detector are AC coupled and pass the charge sensitive preamplifier. A common bias voltage for all channels can be applied at the bias input Lemo connector. It passes a bias filter and feeds each input via a 10 MΩ resistor. The amplified signals pass a variable gain circuit which allows to set the gain from 1 to 15 in 8 steps via manual coder or via remote control. Also the polarity can be adapted to the detector charge polarity. The signals are now split to the shaping amplifiers and to the leading edge discriminators with prefilters (20 ns integration time, 100 ns differentiation time). Their threshold can be set via potentiometer or via RC and a 12 bit DAC. The fast signals are then analysed in the hit decoder, which is able to pick out and calculate the addresses of up to two hits which occur within a coincidence time of 50 ns. This is done within 30 ns. The decoding is fast enough to be ready before the slower shaped signals begin to rise, and are used to switch up to two channels to the output buffer amplifiers. Simultaneously the two 7 bit output DACs are fed with the 4 address bits as lower bits and the 3 address coder bits as higher bits. After 80 ns the output drivers are enabled and put their signals to the analog output bus.

From the hit decoder, a NIM signal is emitted to the trigger / RC bus if no signal is already applied by another MUX-16 unit on the bus. To exclude driver collision with another MUX-16 unit, the position and energy bus drivers are only enabled when there is no signal on the trigger / RC-bus, and are resetted immediately if there is a collision on the trigger / RC-bus. This feature can also be used for fast clear, when an external NIM (current) signal is applied to the trigger / RC bus. So from arbitration logic of the trigger bus, a restriction for the MUX-16 system is: only one module on the same bus may detect up to two input signals within the coincidence time (typ 30..100 ns depending on type). If two different modules get coincident signals, the event is rejected. If remote control is used, the remote control commands are transmitted from MRC-1 module via NIM-bus line as positive pulses (+0.6 V) and do not disturb standard NIM logic. The bus must be terminated on both ends. Usually an additional driver PCB splits the trigger/RC bus in a trigger line and an RC bus line. The trigger/RC line must be terminated at one end, and with the other connects to the PCB. Both PCB outputs, RC and trigger must be terminated.

Technical Data

Top view



Input side (32 channel case version)



Input stage

- Input connector: SubD-25 female connector
- Pin assignment:

Function	connector	Function	connector
Sig-gnd	1,2,7,12,13, 14,15,25	Cha 9	19
Cha 1	11	Cha 10	6
Cha 2	23	Cha 11	18
Cha 3	10	Cha 12	5
Cha 4	22	Cha 13	17
Cha 5	9	Cha 14	4
Cha 6	21	Cha 15	16
Cha 7	8	Cha 16	3
Cha 8	20	guardring	24

Output side (32 channel case version)



- Positive and negative charge can be amplified equally
- The guardring output (24) is connected via R-C-R filter (100 kΩ, 10 nF, 100 kΩ) to the common detector bias inputs

Noise

50MeV type

- 5.5 keV Si + 0.064 keV /pF (1200 e- FWHM + 18 e- /pF)
- maximum input capacity: 100 pF (detector + cable)

100MeV type

6 keV + 0.064 keV /pF

1GeV type

10^{-3} of selected range

Pulser input

The pulser is distributed to all preamplifier inputs

- Tail pulse or square pulse required. The input is not terminated.
- Sensitivity:

50 MeV type:	15 MeV /V $\pm 10\%$
100 MeV type:	27 MeV /V
1 GeV type:	55 MeV /V

As the multiplexer can only detect up to two simultaneous signals, for pulser test an automatic system is implemented: When all channels respond, two channels are picked out and switched to the bus. For the next pulser peak the selected channel address is incremented by one. So with continuous pulser, the selected channel address cycles around. If many MUX-16 modules are connected to one bus, the remote control allows to switch off the outputs of all modules with exception of one, which is then analysed.

Sensitivity

- Sensitivity can be changed by a rotary switch. The following max ranges (3.5 V output) can be set:

50MeV-type

3, 4, 6, 9, 15, 25, 35, 50 MeV

100MeV type

6, 8, 12, 20, 30, 50, 70, 100 MeV

1Gev type

60, 80, 120, 200, 300, 500, 700, 1000 MeV

Discriminators

Input for the 16 discriminators are fast timing filter signals, which are amplified together with the shaper signals. The timing filter stage has an integration time constant of 22 ns and a differentiation constant of 100 ns. The discriminators have a common threshold, which can be adjusted via 10 turn potentiometer or remote control.

The threshold value is available at the sense output. 0.8V of output voltage corresponds to 100 % of the chosen sensitivity range. (80 mV threshold voltage in the 25 MeV range means 10 % which corresponds to 2.5 MeV threshold value).

Outputs

The output pulses from shaper and position DAC can be fed to the same peak sensing ADC.

Shaper outputs (Energy output)

- Unipolar positive gaussian pulse (CR(RC)⁵).
Output amplitude: 0 to 3.5 V, max 20 mA

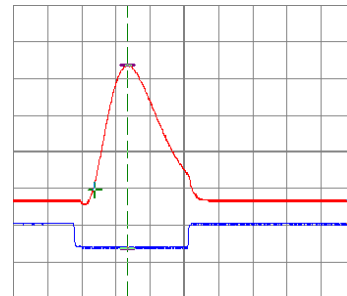

Output signals: Amplitude, NIM-Trigger,
Y=1 V, X= 500 ns

Position outputs

- Unipolar positive pulse (RC). Output amplitude: 22.2 mV increment per bin, 460 mV fixed offset, the address coder gives an additional offset of 355 mV x address. Maximum output range is: 0.46 to 3.3 V, max 20 mA.

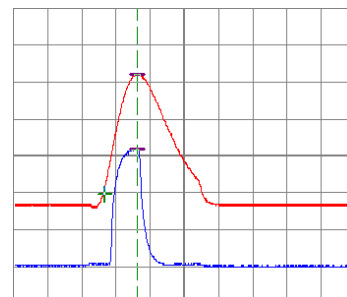

Output amplitude / position , Y=1V, X=500ns

Trigger / RC – Bus

The MUX-16 provides a NIM trigger output created from ored signal of the timing discriminators. The trigger bus line must be terminated at both ends with 50 Ω . It is simultaneously used as remote control bus.

Reject output

A NIM signal is emitted when the module is not allowed to send Amplitude and position data (collision at trigger bus or multiplicity >2).

Detector bias input

- Lemo connector
- Maximum voltage ± 400 V
- When detector side must be on ground level the easiest way is to use a 50Ω terminator, which comes very near to a connection to ground

Power Supply / output connection

Connector: 20 pole flat wire cable

Function	connector	Function	connector
Sig-gnd	2,4,6,8	Power-Gnd	9,10,12,17,18,19,20
Energy output 1	1	+6 V	13,14,15,16
Position output 1	5	-6 V	11
Energy output 2	3		
Position output 2	7		

Power consumption

- +6 V 280 mA
 - -6 V -40 mA
- Tot power = 1.9 W

Due to the low power consumption the PCB can be used in vacuum without cooling.

Dimensions

- Length: 185 mm (with connectors)
- Width: 100 mm
- Height: 16 mm

Driver PCB (V 2.1), 10 V type

A driver PCB for **in vacuum use** is provided which includes strong output drivers to serve ADCs with 10 V input range. It also splits the 20 pole input flat wire to Lemo 00 series outputs for the signals which are amplified by a factor 3.3 to interface to 10 (8 V) peak sensing ADCs.

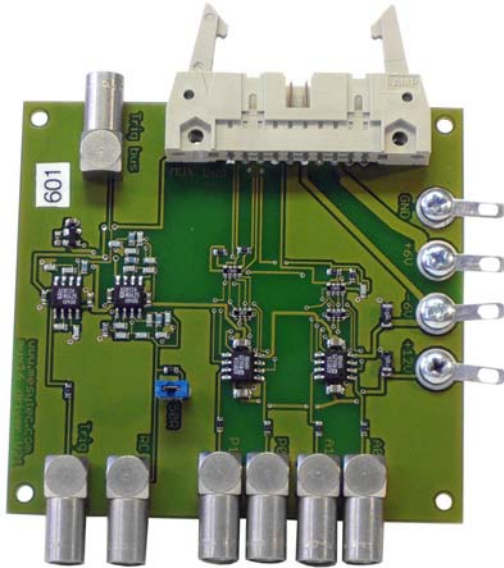

In addition to the 20 pole flat wire, only the MUX-16 trigger output, the RC bus, the pulser input and the detector bias input has to be connected.

Interfacing to MUX-16

1) 20 pole connector:

Function	connector	Function	connector
Sig-gnd	2,4,6,8	Power-Gnd	9,10,12,17,18,19,20
Energy input 1	1	+6 V	13,14,15,16
Position input 1	5	-6 V	11
Energy input 2	3		
Position input 2	7		

Outputs

Lemo 00 for 10 V ADC from left to right (see picture)

1. Position 2 (1.01 V to 7.26 V)
2. Position 1 (1.01 V to 7.26 V)
3. Energy 2 (0 to 10 V)
4. Energy 1 (0 to 10 V)

So for the position output the voltage step between two neighbouring channels is 50 mV.

Other outputs

- Trigger output (must be terminated)
- RC IN/Out (set jumper or terminate with 50 Ω if not used)

Power Supply connector

3.2 mm diameter drills

- gnd
- +6 V (max 2.2 A for 8 modules),
- +12 V
- 6 V

Remote Control

Each module has a rotary switch to set addresses 0 to 7. The address is used to identify the module, and to shift the amplitude coded channel addresses to the right level.

commands

Deactivate MUX

```
SE bus dev 0 set-value
```

Set-value 1 means deactivated, 0 is activated

The "deactivate" feature disables all output drivers. It is important to mask out all devices except one for pulser test.

Set polarity

```
SE bus dev 1 set-value
```

0 is positive and 1 negative charge injection at the input

Set range

```
// A= 3: Write threshold
```

```
SE bus dev 2 set-value
```

The range is 0 to 7

Set threshold

```
SE bus dev 3 set-value
```

The threshold can be set for all channels in common. The value range is 12 bit: 0..4095. The maximum value corresponds to about 80 % of the selected full range.

Set Remote Control on/off

```
ON bus dev
```

```
OFF bus dev
```

Scan bus for connected modules

```
SC bus
```

Returns on/off status and the Module Type ID (= 23)

Example

Readout of a 48 channel silicon strip detector. 3 MUX-16 PCBs are needed, they are connected to one bus. All 3 trigger/RC in/outputs are chained to one Lemo line and terminated at the end. The bus is connected to the driver PCB. Address coders are set to 0, 1, 2.

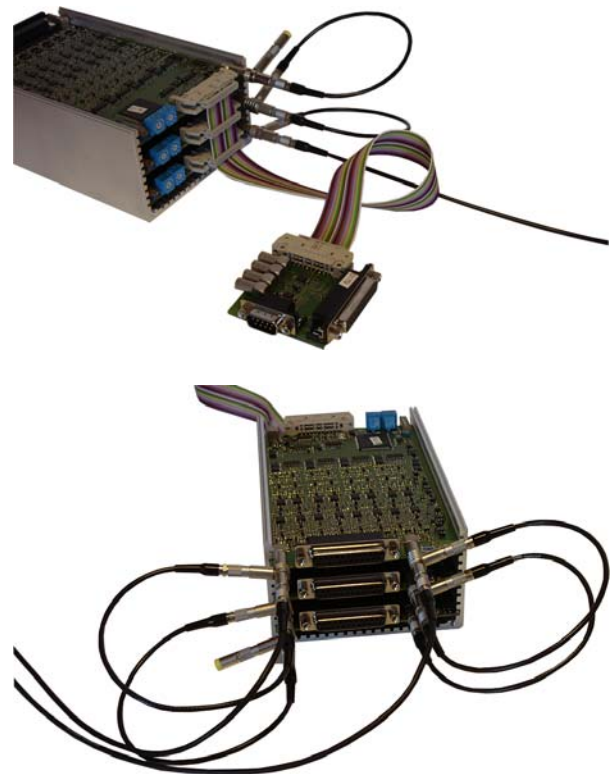

At the rear side, the pulser inputs are chained and terminated at the end. Also all bias inputs are chained to one Lemo cable. The following connections have to be fed through the vacuum vessel (driver PCB inside vacuum):

8 Lemo feedthroughs:

- from driver PCB

1. Energy 1
2. Energy 2
3. Position 1
4. Position 2
5. trigger
6. RC-line

- from MUX-16 stack:

1. Pulser
2. Detector Bias

3 power feedthroughs + ground (to driver PCB)

Power consumption

- +6 V 610 mA
- -6 V 120 mA
- +12 V 25 mA

Outside vacuum connections

The instrumentation outside the vacuum does not differ with the number of MUX-16 devices or channel number of the detector.

The mesytec MRC-1 module is optional, and helps to change settings like sensitivities and thresholds for variable setups which do not allow to break vacuum for adjustments, or if adjustment can only be done with vacuum conditions.

It also allows pulser test with several MUX-16 devices connected to the bus.

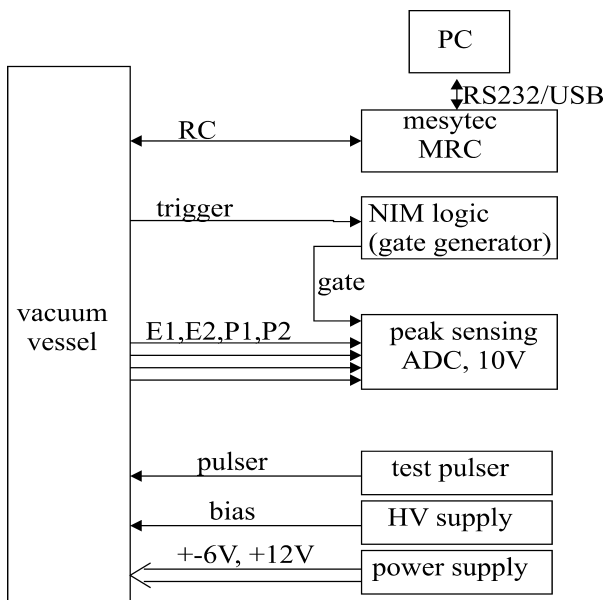
Fast Startup and check:

MUX-16, used with driver PCB

1. Connect power supply to the driver PCB ($\pm 6V$, +12V, gnd).
Check at PCB if all voltages are ok.
2. Connect trigger line (Lemo) between MUX-16 and Driver-PCB. Terminate at the MUX-16 output with T-split and 50 Ω terminator.
3. Connect flat wire between MUX-16 and driver PCB
4. Connect trigger output of driver PCB to a terminated line (scope with terminated input, NIM-input module...)
5. If RC is not used, add jumper to the driver PCB or terminate RC-input with 50 Ω terminator, else connect RC input to the MRC-1 module.
6. Connect a pulser to MUX-16 pulser input.
With correct polarity and gain setting, signals will be visible at all amplitude, position and trigger outputs of the driver PCB.