

mesytec MPRS-16 includes 16 channels of charge sensitive preamplifiers, shapers, timing filter amplifiers and leading edge discriminators. It provides two timing filter outputs, where each is the sum of 8 channels. It also provides a NIM trigger output which is the ORed signal of the discriminators. It is well suited for high resolution timing and ADC gate generation. The input polarity and sensitivity can be selected in 8 steps by a rotary switch. The shaper outputs are designed to connect directly to standard peaksensing ADCs. The modules are especially well suited for single or double sided multistrip silicon detectors.

Features:

- 16 channel compact module
- Includes: preamplifier, shaper, timing filter
- High quality discriminator output (NIM) for good timing resolution or data acquisition start, adjustable threshold.
- Sensitivity and polarity selectable with rotary switch in steps: 0.065, 0.1, 0.15, 0.2, 0.3, 0.5, 0.75, 1.0 * full range.
- Shaper output 10 V @ 1 k Ω , 1 μ s FWHM
- Pulser input
- Bias voltage up to \pm 400 V
- Preamplifier input protection
- PCB module available for vacuum use



Schematics:

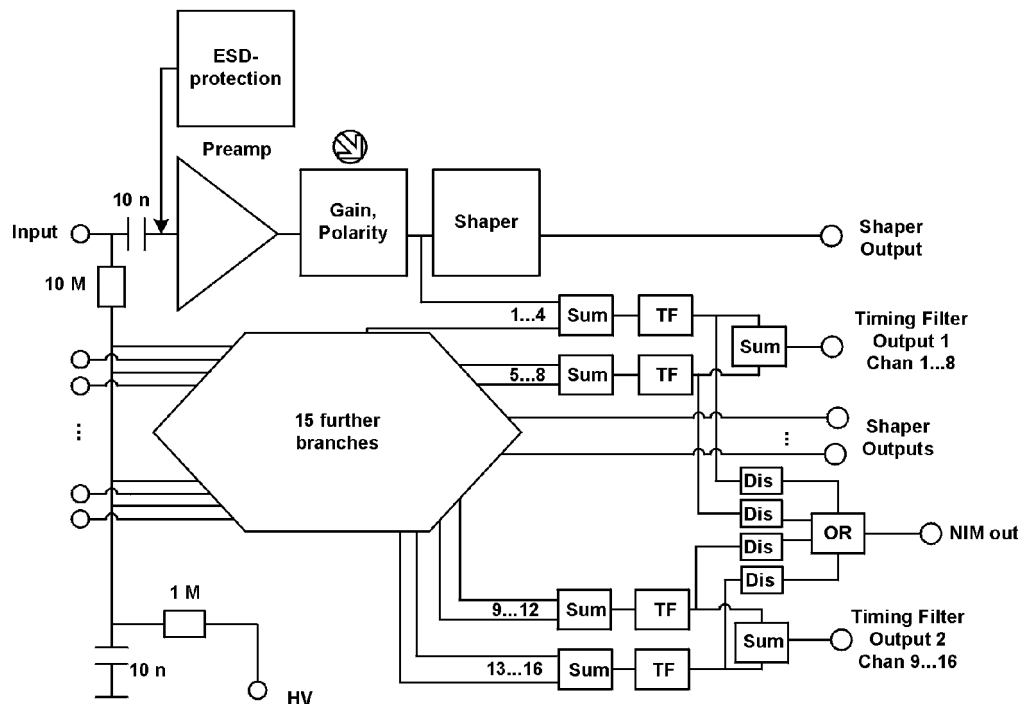

Technical Data

Input stage

- Input connector(s): Sub-D 25 female connector
- Pin assignment:

Function	connector	Function	connector
Sig-gnd	1,2,7,12,13, 14,15,25	Cha 9	19
Cha 1	11	Cha 10	6
Cha 2	23	Cha 11	18
Cha 3	10	Cha 12	5
Cha 4	22	Cha 13	17
Cha 5	9	Cha 14	4
Cha 6	21	Cha 15	16
Cha 7	8	Cha 16	3
Cha 8	20	guardring	24

- Positive and negative charge can be amplified equally.
- The guardring output (24) is connected via R-C-R filter (100 k Ω , 10 nF, 100 k Ω) to the common detector bias input.

Noise

- For 50 MeV full range type (min 15 mVrms)
 - 7.0 keV Si + 0.085 keV/ pF
 - maximum input capacity: 1000 pF (detector + cable)
- For 150 MeV full range type (min 15 mVrms)
 - 10 keV Si + 0.10 keV/ pF
 - maximum input capacity: 1000 pF (detector + cable)

Pulsar input

- Tail pulse, or square pulse, internally not terminated:
- Charge injection per channel:
 - 50 MeV – type: 15 MeV/ V
 - 150 MeV – type: 25 MeV/ V

Sensitivity

- Sensitivity can be changed by a rotaryswitch. The following max ranges (8 V output at the shaper module) can be set: 0.065, 0.1, 0.15, 0.2, 0.3, 0.5, 0.75, 1.0 * full range.

Shaper Outputs

- Unipolar positive gaussian pulse (CR(RC)⁵). Output amplitude: 0 to 10 V, max 50 mA
- Peaking time 790 ns. FWHM 950 ns.
- Crosstalk < 3 * 10⁻³ (-50 dB) to neighbour channel, less than -70 dB to others.

- Pin assignment of 34 pole output connector:
 - pin 1 channel 1, pin 3 channel 2.....
 - pin 2,4,...32, 33, 34 output ground
- Option: low power output stage (max 4 V output signal). Is useful for in vacuum use.

Timing Filter Outputs

The MPRS provides two timing filter outputs. The signals are generated from the sum of channel 1..8 and 9..16. The signals are negative and are scaled and polarized with the rotary switch setting. Output amplitudes : -1.5 V for maximum range in a single channel. The amplitude will vary to some extent with detector capacity and signal risetime.

Discriminators

The MPRS provides a NIM trigger output, which is the or-ed sum of its 4 leading edge discriminators, working each on the analog timing sum of 4 channels. Multiple discriminators are used to provide a high quality low jitter NIM signal. The discriminators have a common threshold, which can be adjusted via 10- turn potentiometer. The threshold value is available at the sense output.

Example:

-1 V threshold voltage in the 25 MeV range means 10 % which corresponds to 2.5 MeV threshold value.

Note that a pulser applied on all channels (for example when applied to the pulser input) will add up in a group of 4 channels, so a pulser corresponding to 0.65 MeV will pass the 2.5 MeV threshold and creates triggers !!

Detector bias input

- Lemo connector
- Maximum voltage ± 400 V
- When detector side must be on ground level: terminate bias input with 50 Ω

Ground connections

- Ground screws on rear side

Power Supply

Connector

- Sub-D 9 connector: 1, 2 = gnd, 3 = +6 V, 4 = +12 V, 5 = -6 V

Power consumption

- With 10 V output driver = 2.0 W
 - +12 V 60 mA
 - + 6 V 220 mA
 - - 6 V - 90 mA
- With 4 V output driver = 1.0 W
 - + 6 V 140 mA
 - - 6 V -20 mA

Due to the low power consumption cooling is not necessary.

Dimensions

- Length: 173 mm (without connectors)
- Width: 105 mm
- Height: 46 mm

Output signals

Upper trace (CH1): shaper output,
lower trace (CH2): NIM trigger output, terminated with 50 Ω.

upper trace: timing output,
lower trace: NIM trigger output

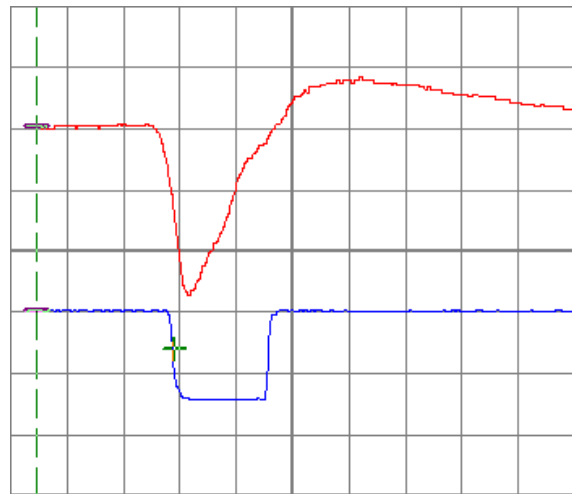

$T = 100 \text{ ns}$, $CH1 = 0.5 \text{ V}$, $CH2 = 0.5 \text{ V}$

upper trace: shaper signal output,
lower trace: NIM trigger output.
Peaking time: from NIM signal to shaper peak **790 ns**

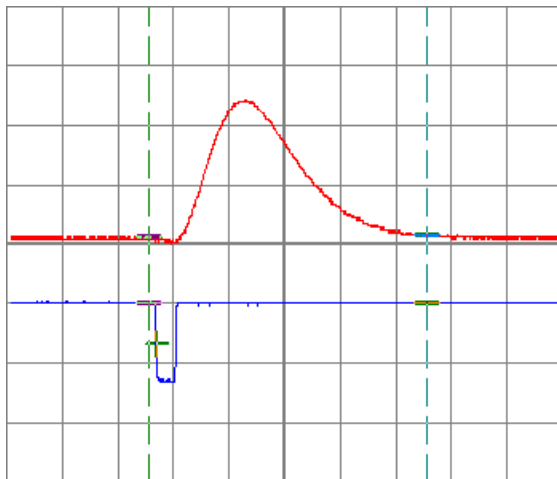

$T = 500 \text{ ns}$, $Ch1 = 2 \text{ V}$, $CH2 = 0.5 \text{ V}$

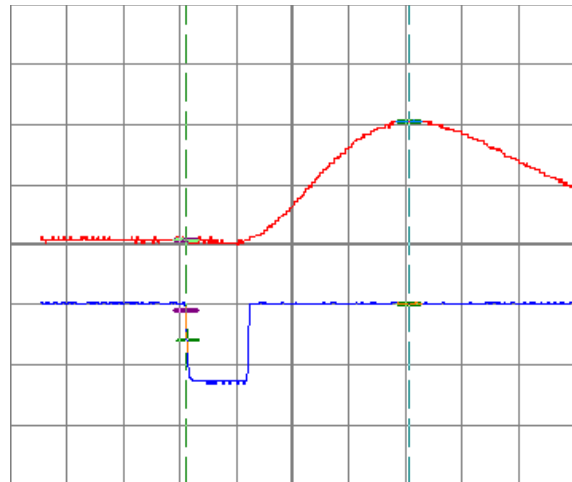

$T = 200 \text{ ns}$, $CH1 = 5 \text{ V}$, $CH2 = 0.5 \text{ V}$

Updated 1.3.2005, power consumption, output signals, scem.